



Ajeenkya DY Patil Journal of Innovation in Engineering & Technology

Journal Homepage: <https://www.adypsoe.in/adypjiet>

Machine Learning Based Predictive Maintenance for Industrial Motors: A Systematic Review and Future Research Direction

¹ Prof. Riyaj Kazi,

² Mrunali Dedunta

³ Tejal Bagade

⁴ Mitali Firodiya

¹ Assistant Professor, Ajeenkya D Y Patil School of Engineering, Pune, INDIA

²⁻⁴ UG student, Ajeenkya D Y Patil School of Engineering, Pune, INDIA

Article History:

Received: 05-01-2026

Revised: 24-01-2026

Accepted: 25-02-2026

Abstract:

Industrial motors are essential components in modern manufacturing systems, and their unexpected failures can result in significant downtime, safety risks, and economic losses. Conventional maintenance strategies such as reactive and preventive maintenance are often insufficient to handle unplanned breakdowns efficiently. In recent years, machine learning (ML)-based predictive maintenance has emerged as a reliable solution for monitoring motor health, detecting faults, and predicting failures at an early stage. This review paper presents an overview of ML techniques applied to predictive maintenance of industrial motors, including supervised, unsupervised, and deep learning approaches. The study focuses on commonly used condition monitoring data such as vibration signals, temperature measurements, and motor current signature analysis. Key challenges related to data imbalance, feature extraction, model interpretability, and real-time industrial deployment are also discussed. Furthermore, recent advancements and representative studies utilizing ML algorithms such as Support Vector Machines, Random Forests, Convolutional Neural Networks, and Recurrent Neural Networks are reviewed. The findings indicate that ML-based predictive maintenance improves system reliability, reduces maintenance costs, and enhances operational efficiency. Future research directions emphasize IoT integration, edge computing, and federated learning.

Keywords: Predictive maintenance, machine learning, industrial motors, vibration analysis, fault diagnosis, condition monitoring.

1. Introduction

Industrial motors are essential components in manufacturing, energy, transportation, and process industries, where their reliable operation is critical for productivity and safety [1]. Harsh operating conditions often lead to wear, degradation, and unexpected failures, resulting in unplanned downtime and financial losses. Traditional maintenance strategies such as reactive and preventive maintenance are commonly employed but are often inefficient, costly, and incapable of preventing sudden breakdowns [2].

The rapid advancement of Industry 4.0 and the widespread adoption of Internet of Things (IoT) technologies have enabled continuous monitoring of industrial motors through real-time sensor data. When combined with Machine Learning (ML) techniques, this data facilitates the implementation of Predictive Maintenance (PDM), which focuses on early fault detection, anomaly identification, and remaining useful life (RUL) prediction [3]. Predictive maintenance allows industries to shift from time-based servicing to condition-based decision-making, significantly improving operational efficiency.

In industrial motor applications, predictive maintenance techniques primarily rely on vibration analysis, acoustic emissions, temperature measurements, and current signature analysis to detect early indicators of mechanical and electrical faults [4]. Machine Learning models such as Support Vector Machines (SVMs), Random Forests, Artificial Neural Networks (ANNs), and deep learning architectures including Convolutional Neural Networks (CNNs) and Recurrent Neural Networks (RNNs) have demonstrated strong capabilities in extracting complex fault patterns from high dimensional sensor data. Advanced signal processing techniques such as Fast Fourier Transform (FFT) and wavelet transforms further enhance fault feature extraction under varying operating conditions [5].

Among various failure modes, imbalance faults pose a significant diagnostic challenge due to their complex nature and sensitivity to dynamic industrial environments. Variations in load, noise interference, and computational constraints make accurate real-time detection difficult using conventional methods. Recent research highlights the effectiveness of combining advanced signal processing with ML-based classification models to improve detection accuracy and robustness. This work aims to leverage both traditional and advanced machine learning approaches to enhance imbalance fault detection in industrial motors, thereby improving system reliability, reducing maintenance costs, and supporting intelligent maintenance strategies [6].

Despite the effectiveness of ML-based predictive maintenance, several challenges limit its widespread industrial adoption. Factors such as data imbalance, operating condition variability, sensor noise, and limited labeled fault data can impact model accuracy. Additionally, the interpretability and real-time deployment of complex learning models remain critical concerns. Addressing these challenges requires robust feature extraction methods and computationally efficient, adaptive learning frameworks.

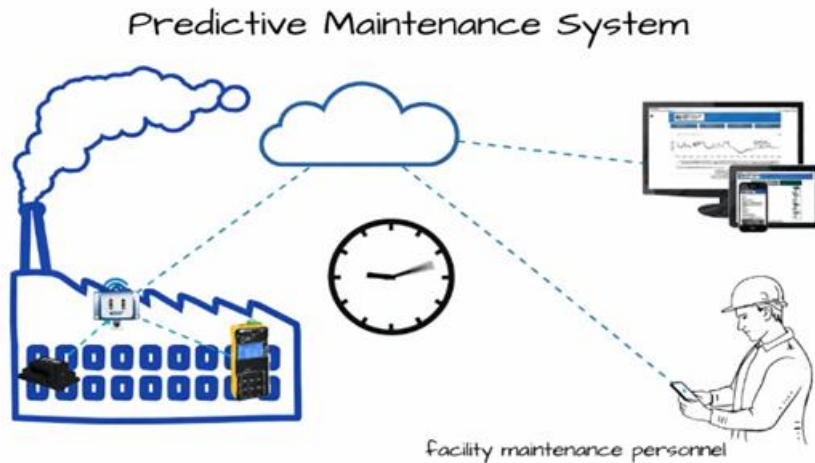

Fig. 1. Predictive maintenance system

2. Literature Survey

Vlachos & Karakatsanis, (2025) developed a fault tolerant PMSM (Permanent Magnet Servo Motor) using machine learning for predictive maintenance in elevators. Authors combined motor topology design, harmonic analysis, and ML based fault diagnosis, validated experimentally with accurate results. This study suggests IoT integration and deep learning for broader industrial use [1].

Ullah et al., (2025) used SVM, KNN, and DNN to the MAFAULDA dataset for vibration-based anomaly detection in induction motors, improving classification accuracy. Their work highlights the potential of hybrid ML–DL approaches for large-scale industrial applications [2].

Zhao et al., (2024) proposed a hybrid decomposition ensemble and Markov process model for forecasting carbon futures, achieving higher prediction accuracy. This method is valuable for global climate policy and financial decision making [3].

Kabir et al., (2024) implemented a transfer learning method with reduced parameters using VGG, Res Net, Squeeze Net, and Vision Transformer, maintaining efficiency. This approach supports high performance even in resource constrained environments [4].

Uribe et al., (2024) designed a GRASP-based multi-objective method for the Facility Layout Problem, using constructive and local search techniques. Authors method improved factory layout design and operational efficiency. Future work involves scalability to dynamic industrial environments [5].

Dong et al., (2024) explored ML based predictive maintain ML based predictive maintenance for machineries used in medical diagnosis that is to be self- supervised pre-training for chest X ray image classification under partial supervision, achieving improved results. ML study addresses medical imaging challenges where labelled data is scarce. Vibration data obtained leads to findings of encouraging further exploration in multimodal medical data [6].

Barrientos-Espillco et al., (2024) integrated YOLOv3 for detection and Bassinet, DeepLabV3+, PSP Net for segmentation to monitor cyanobacterial blooms in lentic waters. The approach enables accurate mapping and supports UAV/IoT-based monitoring. This method can help prevent water quality hazards [7].

Patil et al., (2023) implemented ML-based predictive maintenance for industrial machines using IIOT with SVM, Decision Tree, Random Forest, and Logistic Regression. Their system reduced downtime and outperformed traditional methods. They proposed extending the approach with deep learning for complex fault detection [8].

Mohammed et al., (2023) designed an IoT and ML-based predictive maintenance system for electrical motors using RF, SVM, NB, KNN, and LR. The framework improved scheduling and is well-suited for Industry 4.0 environments. It also allows cloud-based analytics for predictive alerts [9].

Akyaz & Engin, (2024) applied algorithms like regression, decision trees, Naive Bayes, k-NN, SVM, and neural networks for predictive maintenance in yarn machines. Their model optimized maintenance strategies and boosted reliability. This contributes to efficiency gains in textile production lines [10].

Table. 1. Literature survey (1)

| Sr. No. | Author(S) | Year | Findings |
|---------|---------------------------|------|--|
| 1 | Vlachou & Karakatsanis | 2025 | Accurate ML-based PMSM fault prediction |
| 2 | Ullah et al. | 2025 | Improved vibration-based motor detection |
| 3 | Zhao et al. | 2024 | Enhanced carbon price prediction |
| 4 | Kabir et al. | 2024 | Efficient transfer learning models |
| 5 | Uribe et al. | 2024 | Optimized factory layout efficiency |
| 6 | Barrientos-Espillco et al | 2024 | Accurate UAV-based water monitoring |
| 7 | Dong et al. | 2024 | Improved learning with limited data |
| 8 | Patil et al. | 2023 | Reduced industrial machine downtime |
| 9 | Mohammed et al. | 2023 | Improved motor maintenance scheduling |
| 10 | Akyaz & Engin | 2024 | Optimized yarn machine maintenance |

Nalawade & Jakkan, (2024) developed a predictive maintenance system using IIOT, AI, and ML (CNN, RNN, SVM, LSTM) to enhance industrial equipment reliability. The system demonstrated strong accuracy and supports automated alerts. It reduces both unplanned downtime and operational costs [11].

Martins et al, (2024) analysed vibration analysis with ANN, DNN, and Hidden Markov Models for drying press maintenance. Their study improved decision-making in condition-based maintenance

systems. The work shows the potential of vibration data in predictive maintenance strategies [12].

Toso, (2023) used k-NN, Decision Tree, Random Forest, and SVM for predictive maintenance in RDM Group, ensuring effective fault detection. The work shows the importance of vibration data for real-time monitoring. This approach boosted productivity by minimizing unexpected failures [13].

Aminzadeh et al., (2025) deployed ML models (LR, SVM, RF, LSTM) for predictive maintenance of industrial air compressors, improving scheduling. Their work demonstrated the value of advanced data acquisition in PDM. Future research involves integrating IoT sensors for real-time deployment [14].

Akyaz & Engin, (2024) proposed another ML-based predictive maintenance system for yarn machines using regression, k-NN, Gaussian regression, SVM, and neural networks. Their study recommends IoT integration for improved results. They emphasize deep learning as the next step in this area [15].

Theissler et al., (2021) investigated predictive maintenance in the automotive industry using LR, SVM, DT, RF, k-NN, and Naive Bayes. Their findings improved functional safety and reduced lifecycle costs. This demonstrates ML's role in enhancing automotive reliability [16].

Martins et al., (2024) determined HMM, neural networks, DNN, and K-means for predictive maintenance of drying presses. This advanced method enhanced monitoring and equipment availability. The study suggests extending the methodology to other industrial machines [17].

Ucar et al., (2024) reviewed AI applications in predictive maintenance using regression, SVM, RF, ANN, CNN, and RNN. Their paper emphasized trustworthiness, explainability, and future trends in AI-driven PDM. The review stressed hybrid AI approaches for broader adoption [18].

LeClerc, (2022) implemented logistic regression and Naive Bayes for predictive monitoring of polyphase motors in distribution centres. The results improved motor fault detection and scheduling. The method can scale to larger logistics automation systems [19].

Mohammed et al., (2023) presented an IoT and ML-based PDM system for electrical motors, achieving better reliability and reduced downtime. Hybrid models were recommended for higher accuracy. Author suggests cloud integration for industry-wide adoption [20].

3. Gap Analysis:

The gap analysis of existing research on ML-based predictive maintenance highlights several critical limitations and opportunities for future work. Although numerous studies have demonstrated progress in areas such as fault detection, predictive modelling, vibration analysis, and IoT integration, most research remains focused on specific machines or industrial domains, such as elevators, yarn machines, drying presses, or automotive systems, which limits the generalizability of the models across diverse industrial environments [7]. Scalability and real-time deployment of predictive maintenance solutions are still underexplored, particularly for large-scale industrial operations or resource constrained settings, where efficient computation and reduced model complexity are essential [8]. While hybrid ML DL approaches and deep learning techniques show significant potential for improving fault detection accuracy and predictive performance, these methods are not yet widely implemented, and their integration with real-time IoT systems remains

limited. Additionally, challenges persist in handling incomplete, partially labelled, or noisy data, which is common in industrial and medical applications, emphasizing the need for self-supervised or semi-supervised learning strategies [9].

Table. 2. Literature survey findings (2)

| Sr. No. | Author(s) | Year | Findings |
|----------------|-------------------|-------------|--|
| 1 | Nalawade & Jakkan | 2024 | Reduced downtime and costs |
| 2 | Martins et al. | 2024 | Improved vibration-based decisions |
| 3 | Toso | 2023 | Enhanced real-time fault detection |
| 4 | Aminzadeh et al. | 2025 | Improved compressor maintenance scheduling |
| 5 | Akyaz & Engin | 2024 | Enhanced IoT-based yarn maintenance |
| 6 | Theissler et al. | 2021 | Reduced automotive lifecycle costs |
| 7 | Martins et al. | 2024 | Improved drying press monitoring |
| 8 | Ucar et al. | 2024 | Identified AI-PdM future trends |
| 9 | LeClerc | 2022 | Improved motor fault detection |
| 10 | Mohammed et al. | 2023 | Enhanced motor reliability via IoT |

Explainability, interpretability, and trustworthiness of AI models are other critical gaps, as stakeholders often require transparent decision-making to adopt predictive maintenance in practice. Moreover, operational challenges such as unplanned downtime, high maintenance costs, and effective utilization of cloud-based analytics for predictive scheduling require further optimization [7].

Overall, these gaps indicate a pressing need for comprehensive, scalable, and explainable ML-based predictive maintenance frameworks that can operate reliably in real-world industrial environments, integrating advanced sensor data, edge computing, and IoT-enabled monitoring to enhance efficiency, reduce costs, and improve equipment reliability.

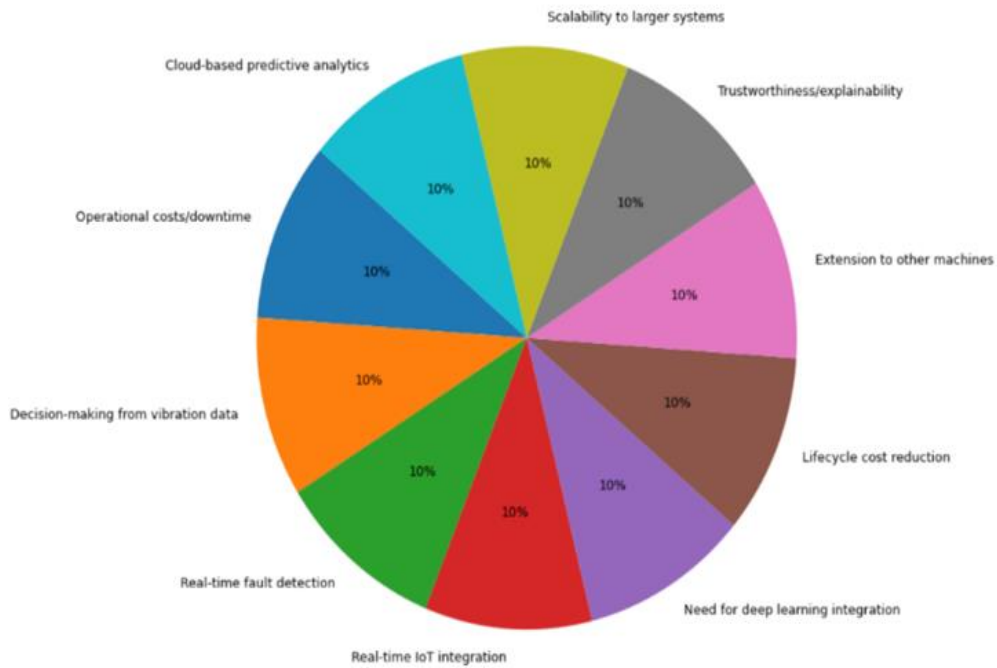

Fig. 1.2 Gap Analysis

Table. 3. Literature survey findings (3)

| Sr. No. | Author(S) | Gap identified | Analysis |
|---------|-------------------|--|---|
| 1 | Nalawade & Jakkan | Unplanned downtime and operational costs | IIoT and ML PdM enhanced equipment reliability. |
| 2 | Martins et al. | Decision-making from vibration data | ANN, DNN, HMM improved maintenance decisions |
| 3 | Toso | Real-time fault detection | ML models reduced unexpected failure |
| 4 | Aminzadeh et al. | Real-time IoT integration | ML PdM improved air compressor scheduling |
| 5 | Akyaz & Engin | Need for deep learning integration | ML PdM suggested IoT and deep learning. |
| 6 | Theissler et al. | Lifecycle cost reduction | ML PdM improved automotive safety and costs |
| 7 | Martins et al. | Extension to other machines | HMM, DNN, K-means enhanced machine monitoring. |
| 8 | Ucar et al. | Trustworthiness and explainability | Review highlighted hybrid AI for PdM adoption |
| 9 | LeClerc | Scalability to larger systems | ML improved motor fault detection in logistics. |

| | | | |
|----|-----------------|----------------------------------|---|
| 10 | Mohammed et al. | Cloud-based predictive analytics | IoT and ML PdM enhanced reliability and accuracy. |
|----|-----------------|----------------------------------|---|

4. Methodology

The methodology for developing a machine learning-based predictive maintenance system for industrial motors focuses on a systematic approach to data acquisition, processing, model development, and fault prediction. Predictive maintenance relies on real-time condition monitoring and intelligent algorithms to anticipate motor failures before they occur. The proposed methodology integrates industrial sensors, data-driven analytics, and machine learning techniques to detect abnormal motor behavior and estimate remaining useful life (RUL).

Key stages of the methodology involve collecting multi sensor data such as vibration, temperature, current, and acoustic signals from industrial motors under various operating conditions. The collected data is pre-processed to remove noise and extract meaningful features through statistical, time frequency, and signal-processing techniques. These features are then used to train supervised learning models including Support Vector Machines (SVM), Random Forests, k-Nearest Neighbours (k-NN), and Neural Networks for classification and fault prediction.

The methodology further involves model evaluation using performance metrics such as accuracy, precision, recall, F1 score, and confusion matrix to ensure reliability. Once validated, the trained model is deployed alongside real-time monitoring hardware to continuously evaluate motor health and generate early alerts for potential faults. This structured methodology ensures accurate fault detection, reduced unplanned downtime, and improved operational efficiency in industrial environments.

1.1 Software requirement:

- Operating System: - Windows 10 / Linux (Ubuntu)
- Programming Language: - Python 3.x
- Development Environment: - Jupyter Notebook
- Data Processing & Analysis Libraries: - NumPy, Pandas, SciPy
- Machine Learning Libraries: - Scikit-learn (Random Forest, SVM)
- Data Visualization Tools: - Matplotlib, Seaborn • Database Management: - MySQL / SQLite (for sensor data and maintenance logs) **System Modules**

1.2 Algorithm:

- Input: CSV DATASET (Temperature, Vibration, Pressure, Usage .
- Output: Predicted machine condition.

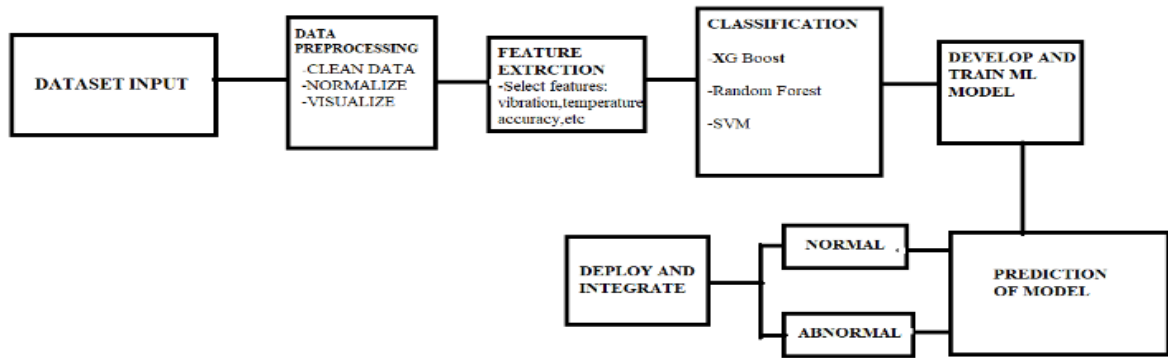

Fig. 1.2.1 Block diagram of proposed system

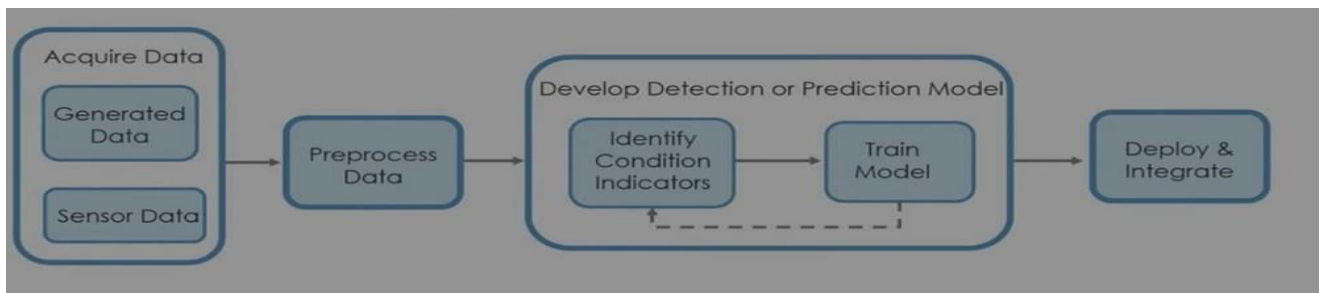

Fig. 1.2.2 Flow chart of proposed system

Flow chart description:

- Acquire Data: Collect data from sensors (vibration, temperature, etc.) and generated datasets.
- Preprocess Data: Clean, filter, and prepare the data for analysis.
- Develop Model: Identify Condition Indicators: Extract key features showing motor health.
- Train Model: Use machine learning to predict faults or remaining life.
- Deploy & Integrate: Implement the trained model in real systems for real-time fault prediction and maintenance alerts.

Limitations and Future Scope

Limitations:

1. The model is trained on a CSV dataset, which may not fully represent real-time industrial conditions.
2. Lack of hardware integration, so real sensor data is not captured dynamically.
3. Model performance depends on data quality and size; inaccurate data can affect predictions.
4. Limited to selected parameters (vibration, temperature, voltage, current) and may not include all fault indicators.
5. Does not consider real-time streaming or live monitoring, only batch data processing.

Future Scope

1. Integration with real-time sensors and IoT devices for live data collection.
2. Implementation of real-time monitoring dashboard for continuous motor health tracking.
3. Use of advanced models like deep learning (LSTM, ANN) for improved prediction accuracy.
4. Expansion to include more parameters such as pressure, sound, and humidity.
5. Deployment in actual industrial environments for practical validation and scalability.

Applications:

1. Manufacturing plants- Monitoring motors in conveyor belts, presses, and automated machinery.
2. Energy Sector- Fault detection in turbines, compressors, and power plant motors.
3. Transportation - Predictive maintenance for railway engines, electric vehicles, and aircraft motors.
4. Oil & Gas Industry Monitoring pumps, compressors, and drilling equipment.
5. Automation & Robotics-Ensuring reliability of actuators and servo motors.
6. Smart Factories (Industry 4.0) Integration with lot for real time predictive maintenance.

5. Conclusion

Machine Learning–based Predictive Maintenance for Industrial Motors successfully demonstrates that leveraging machine learning algorithms along with historical and real time sensor data provides a powerful solution for enhancing the reliability, efficiency, and longevity of industrial motors. By continuously monitoring critical parameters such as vibration, temperature, current, and operational load, the system can detect early signs of wear and abnormalities, predict potential failures, and estimate the remaining useful life (RUL) of motors with high precision. Compared to traditional reactive and preventive maintenance methods, this predictive maintenance approach significantly reduces unplanned downtime, lowers maintenance and repair costs, minimizes the risk of catastrophic motor failures, and ensures uninterrupted production processes. The adaptability of machine learning models allows the system to handle diverse motor types, varying operational

conditions, and complex industrial environments, making it highly scalable and robust. Moreover, the integration of predictive maintenance into industrial workflows supports the transition toward Industry 4.0 by enabling data-driven decision-making, optimized resource utilization, and improved overall operational efficiency. Overall, this project highlights the transformative potential of combining artificial intelligence, machine learning, and Industrial Internet of Things (IIOT) technologies to create intelligent, cost-effective, and proactive maintenance strategies that can revolutionize modern industrial practices and promote sustainable, high performance manufacturing operations.

References:

1. V. I. Vlachos and T. S. Karakatsanis, "Development of a fault-tolerant permanent magnet synchronous motor using a machine-learning algorithm for a predictive maintenance elevator," *Machines*, vol. 13, no. 5, 2025.
2. I. Ullah, N. Khan, S. A. Memon, W.-G. Kim, J. Saleem, and S. Manzoor, "Vibration-based anomaly detection for induction motors using machine learning," *Sensors*, vol. 25, no. 3, p. 773, 2025.
3. Y. Zhao, W. Zhang, X. Gong, and X. Liu, "Carbon futures return forecasting: A novel method based on decomposition ensemble strategy and Markov process," *Expert Systems with Applications*, vol. 229, 2024.
4. H. M. D. Kabir, S. K. Mondal, S. B. Alam, and U. R. Acharya, "Transfer learning with spinally shared layers," *Expert Systems with Applications*, vol. 231, 2024.
5. N. R. Uribe, A. Herrán, and J. M. Colmenar, "A GRASP method for the bi-objective multiple row equal facility layout problem," *Expert Systems with Applications*, vol. 230, 2024.
6. N. Dong, M. Kampffmeyer, H. Su, and E. Xing, "An exploratory study of self-supervised pre-training on partially supervised multi-label classification on chest X-ray images," *Expert Systems with Applications*, vol. 228, 2024.
7. F. Barrientos-Espillco, M. J. Gómez-Silva, E. Besada-Portas, and G. Pajares, "Integration of object detection and semantic segmentation based on convolutional neural networks for navigation and monitoring of cyanobacterial blooms in lentic water scenes," *Expert Systems with Applications*, vol. 227, 2024.
8. C. R. Patil, S. K. Jadhav, A. L. Bardiya, A. P. Davande, and M. P. Raverkar, "Machine learning-based predictive maintenance of industrial machines," *ResearchGate*, Mar. 2023.
9. N. A. Mohammed, O. F. Abdulateef, and A. H. Hamad, "An IoT and machine learning-based predictive maintenance system for electrical motors," *ResearchGate*, Aug. 31, 2023.
10. T. Akyaz and D. Engin, "Machine learning-based predictive maintenance system for artificial yarn machines," *IEEE Xplore*, Sept. 16, 2024.
11. N. Nalawade and S. D. Jakkan, "Predictive maintenance for industrial equipment using IIoT, AI and ML," *International Journal of Advanced Research in IT and Engineering*, vol. 10, no. 6, 2024.
12. A. Martins, I. Fonseca, J. T. Farinha, J. Reis, and A. J. M. Cardoso, "Prediction maintenance based on vibration analysis and deep learning — A case study of a drying press supported on a hidden Markov model," *Expert Systems with Applications*, vol. 230, 2024.
13. R. Toso, "Predictive maintenance based on vibrational analysis and machine learning in RDM Group,"

Politecnico di Torino Thesis, 2023 2024.

- 14.A. Aminzadeh, S. S. Karganroudi, S. Majidi, C. Dabompre, K. Azaiez, C. Mitride, and E. Sénéchal, "A machine learning implementation to predictive maintenance and monitoring of industrial compressors," *Sensors*, vol. 25, no. 4, p. 1006, 2025.
- 15.A. Ucar, M. Karakose, and N. Kırımça, "Artificial intelligence for predictive maintenance applications: Key components, trustworthiness, and future trends," *Applied Sciences*, vol. 14, no. 2, 2024.
- 16.D. M. LeClerc, "Machine learning-based predictive methods for polyphase motor condition monitoring," *Purdue University Thesis*, 2022.
- 17.Ucar, Aysegul, Mehmet Karakose, and Necim Kırımça. "Artificial Intelligence for Predictive Maintenance Applications: Key Components, Trustworthiness, and Future Trends." *Applied Sciences*, vol. 14, no. 2, 2024.
- 18.LeClerc, David Mathew. "Machine Learning-Based Predictive Methods for Polyphase Motor Condition Monitoring." *Purdue University Thesis*, 2022.
- 19.Mohammed, Noor A., Osamah F. Abdulateef, and Ali H. Hamad. "An IoT and Machine Learning-Based Predictive Maintenance System for Electrical Motors." *ResearchGate*, 18 July 2023.A. Theissler, J. Pérez-Velázquez, M. Kettelgerdes, and G. Elger, "Predictive maintenance enabled by machine learning: Use cases and challenges in the automotive industry," *Computers & Industrial Engineering*, vol. 158, 2021.
- 20.A. Theissler, J. Pérez-Velázquez, M. Kettelgerdes, and G. Elger, "Predictive maintenance enabled by machine learning: Use cases and challenges in the automotive industry," *Computers & Industrial Engineering*, vol. 158, 2021.